

# GIRL SCOUTS PLANNING CEREMONIES



# Girl Scouts Planning Ceremonies

## Table of Contents

Why Have a Ceremony?.....	4
What Makes a “Good” Ceremony?.....	4
Traditional Girl Scout Ceremonies and Celebrations.....	5
Girl Scout Troop .....	5
Girl Scout Special Days.....	5
Other Ceremonies and Celebrations .....	6
Resources.....	6
Helping Girls Plan Their Ceremony .....	8
Girl Planning:.....	8
Basic Guidelines for Creating your Own Ceremonies:.....	8
Tips for Holding Ceremonies:.....	9
Setting the Atmosphere:.....	9
Symbols Used in Ceremonies:.....	10
Colors: .....	11
Candles:.....	11
Ceremony Planner .....	12
SPECIAL CLOSINGS .....	14
Clean Up.....	14
Magic Tunnel.....	14
Good-bye Song.....	14
Girl Scout Good-bye Song.....	14
Girl Scout Out.....	14
Friendship Circle with Friendship Wish.....	14
Spread Arm Good-bye Circle.....	15
Native American Benediction .....	15
Taps.....	15
CANDLE LIGHTING INVESTITURE AND REDEDICATION .....	16
SAMPLE DAISY INVESTITURE.....	17
SAMPLE DAISY INVESTITURE CEREMONY .....	18
BROWNIE POND INVESTITURE.....	19

SAMPLE REDEDICATION #1 .....20

GORP REDEDICATION.....21

HOW TO BAKE A BROWNIE.....23

DAISY BRIDGING TO BROWNIE CEREMONY.....24

GIRL SCOUT’S OWN.....25

WAGGGS Friendship Knot Instructions.....26

WORLD FLAG CEREMONY .....27

AMERICAN FLAG PROTOCOLS.....28

    Rules for Display of the American Flag: .....28

    Raising and Lowering the Flag: .....28

    Participants in Flag Ceremony: .....28

    Flag Folding: .....29

    Retiring a Worn Flag: .....29

CALLS FOR A FLAG CEREMONY .....30

FLAG (RECIPE) CEREMONY .....31

This manual is dedicated in memory to Katie Jimenez, our wonderful and wise Girl Scout leader, trainer, and mentor. She curated, created, and shared many ceremonies so that Girl Scout traditions and songs remain alive and relevant for all Girl Scouts.

*I'd like the memory of me to be a happy one,  
I'd like to leave an afterglow of smiles when life is done.  
I'd like to leave an echo whispering softly down the ways, of happy times and laughing times  
and bright and sunny days.  
I'd like the tears of those who grieve, to dry before the sun of happy memories that I leave  
behind when day is done.  
-- Katie Jimenez*

# Girl Scouts Planning Ceremonies

---

## Why Have a Ceremony?

A ceremony is a way to make a meaningful occasion special. There are traditional Scouting ceremonies as well as ceremonies the girls want to create on their own to mark special times. Ceremonies celebrate special times allowing girls to reflect on those moments. They renew the Girl Scout Promise and commitment to follow the Girl Scout Law, recognize accomplishments, and reinforce the belief in the values of Girl Scouting. Ceremonies give us an opportunity to celebrate, inspire, thank, and appreciate each other and our efforts and express feeling, friendship, patriotism, and service. Ceremonies may be informal, taking a few minutes to prepare, or more formal – requiring advanced preparation by the girls.



Ceremonies should be creative and they should be an opportunity for your girls to express their feelings and share their knowledge gained through their experiences as an individual as well as part of your troop. Your girls have wonderful ideas – be sure to include them in each step of the planning to give them a sense of ownership and pride of accomplishment as the ceremony unfolds. Suggestions for working with girls to plan their Girl Scout ceremonies and some sample ceremonies are included in these materials. Ceremonies in your troop help establish their own traditions and can be an occasion to share with their parents, family and friends. Girls can offer service to their wider community by providing Flag Ceremonies for various organizations. Older girls may plan bridging ceremonies for younger troops and may also plan ceremonies for their Service Unit, Region or Council.

## What Makes a “Good” Ceremony?

<b>Girl Planning!</b>	<b>Purpose</b>	<b>Imagination</b>	<b>Inspiration</b>	<b>Theme</b>
<b>Symbolism</b>	<b>Simplicity</b>	<b>Creative</b>	<b>Tradition</b>	<b>Joy</b>
<b>Active Participation by Everyone</b>		<b>Recognition</b>	<b>Meaningful</b>	<b>Dignity</b>

# Traditional Girl Scout Ceremonies and Celebrations

## Girl Scout Troop

- ♥ **Opening Ceremony:** Simple, short ceremony to start a meeting such as saying the GS Promise and Law, singing a song, reciting a poem, raising the flag, playing a short game, or discussing a Girl Scout concept. This officially starts the meeting (or event), adding structure especially for Daisy, Brownie, and Girl Scout Juniors. Use a Kaper Chart to assign girls to plan or take special parts of the opening and closing ceremonies.
- ♥ **Closing Ceremony:** Short, simple ceremony to officially end a meeting (or event) silently, noisily, lively or solemnly. Girl Scouts often use a Friendship Circle, singing Taps or a good-bye song, or a Magic Tunnel to say good-bye. Clean-up should occur before the Closing Ceremony. Ask parents to wait for the meeting to close before taking their girls home.
- ♥ **Investiture Ceremony:** Girls and adults joining Girl Scouts for the first time recite the Girl Scout Promise and are welcomed to Girl Scouting. They receive the appropriate membership pin (Girl Scout Daisy pin for Daisies, Brownie Girl Scout pin for Brownies, or Trefoil Girl Scout pin for everyone else). Individuals are invested only once in their lifetime.
- ♥ **Rededication Ceremony:** Girl Scouts (girls and adults) already invested renew their Girl Scout Promise and Law. This can be combined with an Investiture for new Girl Scouts.
- ♥ **Court of Awards:** A ceremony to honor and recognize accomplishments (earned insignia). Thank others who have helped the troop/group with their efforts.
  - " **Journey Ceremony:** Girl Scouts who have earned the final award along a Journey are honored, often with a themed celebration including family and friends.
- ♥ **Pinning Ceremony:** celebrates Girls receiving program-level Girl Scout pins
- ♥ **Bridging Ceremony:** Girl Scouts move from one program level to another after fulfilling bridging requirements and receive their bridging recognition.
  - " **Brownies Fly-Up** when they continue as Girl Scout Juniors. Only Brownies who continue as a Juniors receive and can wear Brownie wings. This is separate from Brownie bridging requirements.
- ♥ **Bronze, Silver, Gold Award Ceremony:** honors Juniors, Cadettes, Seniors, & Ambassadors for projects that meet award criteria. Silver and Gold Awardees are also honored by their Service Unit and the GSGLA Council.
- ♥ **Girl Scout's Own:** Quiet inspirational ceremony planned and carried out by the girls where they express their feelings about a particular theme
- ♥ **Leader Appreciation Day:** Recognize your Troop Leader and other adults helping your troop
- ♥ **Patrol Leader Installation:** Each time new patrol leaders are selected, girls receive (or transfer) the double gold cords for their position



## Girl Scout Special Days

- ♥ **October 31 - Founder's Day Ceremony:** Recognizes the importance of Juliette Low in promoting Girl Scouting on her birthday, October 31

- ♥ **February 22 - Thinking Day Ceremony/Celebration:** Celebrates Girl Scouting & Girl Guiding around the world on the birthdays of both Lord Baden-Powell and Lady Baden-Powell. This is a good time for new scouts to receive the World Trefoil pin.
- ♥ **March 12 - Girl Scout Birthday Ceremony/Celebration:** Recognizes the start of Girl Scouting in the USA on March 12, 1912
  - " **Girl Scout Week:** the week of Mar 12 (Sun to Sat)
  - " **Girl Scout Sunday/Sabbath (Shabbat):** reflections on the words "to serve God" in the Girl Scout Promise. Consider contacting your troop's churches and synagogue to have this acknowledged to the congregation.
- ♥ **April 22 – Leader Appreciation Day:** Have the troop recognize your Troop Leader and other adults working with your troop. Consider nominating your leader(s) for the *First Year Leader Award* or *Leader with a Heart Award* by contacting your Service Unit Awards Chair or Service Unit Manager.



## Other Ceremonies and Celebrations

- ♥ **Flag Ceremony:** Patriotic ceremony to honor the flag of the United States with a Flag Raising and Flag Lowering Ceremony. Older girls may honor a worn flag in a Flag Retirement Ceremony during a camping trip. Proper flag etiquette is observed at all times.
- ♥ **Candle Lighting Ceremony:** Candle (or flashlight) ceremony to remind people of the words and meaning of the Girl Scout Promise and Law
- ♥ **Thanks:** Appreciation for help from Troop Committee and/or sponsors. (Check pinterest for ideas)
- ♥ **Special Days:** Recognize a special day like Earth Day or United Nations Day.
- ♥ **Campfire:** The meaning of a campfire lies in the spirit of the program. It can unlock the spirit of sisterhood, mystery, romance, humor, and magic within the heart of each participant.
- ♥ **Campfire Ashes:** Ashes taken from a cold campfire are sprinkled into the flames of the next campfire to carry on the tradition of fellowship. Dates and places of all ashes sprinkled into a campfire are combined, recorded and passed on by girls present at the campfire. As girls travel, the campfire ashes circle the globe.
  - " *We carry our fellowship with us from other campfires with our friends from other lands. May the joining of the dead fires with leaping flames of our campfire tonight symbolize once more the unbroken chain that binds Girl Scouts and Girl Guides around the world – with greetings from (list place and dates). Will anyone else with campfire ashes please come forward and join me. We will now add the ashes and fellowship they represent to this campfire. “*

## Resources

Girl Scout ceremonies are not required to follow a set procedure but may open, carry out the purpose, and close in a number of ways. The ages of the girls, the season, location, and the purpose of the ceremony will help determine what goes into the ceremony. A group may build up a repertory of songs and collect a file of poems, readings and quotations to be used in ceremonies. Helpful links for ideas and source of many ideas copied herein:

<http://www.girlscouts.org/program/basics/traditions/ceremonies/>

[http://www.girlscoutsjs.org/phocadownload/GeneralMembership/gsjc\\_ceremonies\\_2011.pdf/](http://www.girlscoutsjs.org/phocadownload/GeneralMembership/gsjc_ceremonies_2011.pdf/)

[www.pinterest.com/girlscoutsla/thank-you-volunteers](http://www.pinterest.com/girlscoutsla/thank-you-volunteers) <http://scoutingweb.com>

<http://guidezone.e-guiding.com>

[http://www.gsofsi.org/forms/leaders/ceremony/ceremony\\_091108.pdf](http://www.gsofsi.org/forms/leaders/ceremony/ceremony_091108.pdf)

... and other web searches

Look for Ceremonies in Girl Scouting from older leaders or Amazon or ebay (currently not in print) \_\_\_\_\_

## Helping Girls Plan Their Ceremony

### **Girl Planning:**

- Involve girls in planning ceremonies at all program levels, keeping progression in mind.
- Solicit ideas (give choices to younger girls) from suggestions for purpose, format, formality, etc.
- Work with a committee, patrol, or Court of Honor as necessary
- Explain purpose and form of ceremony (begin – carry out purpose – end)
- Discuss appropriate behavior
- Involve girls by writing parts, serving as hostesses and mistress of ceremonies, making invitations and decorations, etc.
- Practice more formal ceremonies a few times to allow girls to gain confidence in their parts. Be prepared to guide with cues like “Jane will now read a poem on friendship.”

### **Basic Guidelines for Creating your Own Ceremonies:**

adapted from “My Keys to Creative Ceremonies”

#### **1. What is the purpose of this ceremony?**

For example. Does a flag ceremony have a deeper purpose than to open a meeting?

Does an initiation or investiture have a purpose beyond welcoming new members? Do the girls share their efforts or knowledge gained when earning a recognition?

#### **2. What is your theme?**

Sometimes this is dictated by the ceremony: Flag ceremonies often revolve around “My Country”;

Investiture and Rededication can reflect on oaths or meanings of laws. It’s fun to choose a different kind of theme and plan a ceremony around that! Such as: My Friends, Trees, Stars, the Ocean, Diversity...

#### **3. What are your thoughts and feelings about the theme?**

Have the girls think about the theme and share their ideas and thoughts with everyone.

Ask them, “How do you feel about it?” “Why is this important to you?” Some answers might reflect their pride or thankfulness.

#### **4. Which ones do you want to express in *this* ceremony?**

The most effective ceremonies concentrate on one central thought, so ask the girls which feeling from the ones we discussed (see #3) do you want to express in *THIS* ceremony?

#### **5. How shall you express your thoughts and feelings?**

Is this ceremony a sharing of experiences or thought? Shall you use Poems? Stories? Skits? Music? Art? Do you want to create a special atmosphere? Do you want to use any special symbolism? What kind?

#### **6. What should be included in the ceremony?**

Have a beginning, carry out your purpose, and end. Identify any materials needed to establish your atmosphere, provide music, or symbolism. How will you use your props to be meaningful and fun?

#### **7. Should guests be invited?**

Do we hold this ceremony for ourselves or invite parents or entire families? Do we extend invitation to friends, another Girl Scout troop, adults in Girl Scouting or adults from the community? Will the girls make invitations?



**8. Where the ceremony should be held?**

Do we hold the ceremony indoors or outdoors? Do we need a place with a view? Is there a park or location near water?

**9. When should the ceremony be held?**

Will this ceremony be during troop meeting time or another time? On a weekend or weekday, in the morning or at night?

**10. How will we do it?**

Who will start the ceremony? Where will people sit or stand? Do the girls speak together or individually? Is there something new to learn? Do you need to rehearse?

**Tips for Holding Ceremonies:**

- Provide sufficient time to plan the ceremony.
- Use *Journey Adult Guides* and *The Girls Guide to Girl Scouting* to help girls plan.
- Take safety precautions when using candles or fires or constructing bridges or platforms. Refer to [Volunteer Essentials](#) and the [Safety Activity Checkpoints](#) for specific advice.
- Add personal elements to traditional ceremonies.
- Consider the role of color and symbols that the girls might use in their ceremony.
- Observe flag etiquette when girls have flag ceremonies.
- Use your computer to print out certificates dressed up with pictures from the girls' efforts to earn recognitions. (You may want to print these double sided and fold it in half)

**Setting the Atmosphere:** The right atmosphere helps create effective ceremonies

**MUSIC** helps set an atmosphere

A **SPECIAL PLACE** helps set an atmosphere and expectations

**SILENCE** helps set an atmosphere – used especially in Girl Scout's Own, i.e.

Walking UNDER a (hand) ARCH can be a signal for silence

A TOUCH passed from one to another can be a signal for silence

A **SYMBOL** is something that stands for something else. In ceremonies, a symbol often stands for a more abstract ideal or idea.

All sample ceremonies in this handout can be used as is or portions taken and rewritten to make a special ceremony for your troop. You can take portions of a re-dedication and add it to a bridging ceremony and of course, a flag ceremony can be used at any time as an opening to your main ceremony. Encourage your girls to take part in each step and give them the chance to really make it something special for them.

## Symbols Used in Ceremonies:

Archway	The entering of a different atmosphere or phase
Bridge	A crossing over, usually between program levels
Dove and Olive Branch	Peace
Eagle	Courage
Flag	The banner of Girl Scouting, troop/group, council, state or country
Friendship Circle	Unbroken chain of friendship with Girl Scouts and Girl Guides
Friendship Stick	We are a sister to every Girl Scout
Friendship Knot	Made by a friend
Feather	Nature
Handshake	Hello, welcome
Lighted Candle	Symbol of individuality. Puts attention on a concept
Pebble	Nature
Planting a tree	Conservation
Quiet Sign	Quiet
String/Yarn	The human line that binds us all together
Signing/Saying your Name	Your own identity
Swaying side by side	Everyone agreeing to the same thought
Trefoil	The three parts of the Girl Scout Promise
Wishing Well	Hopes and Dreams

**LIGHT** can be a symbol.

What might the light of a single candle symbolize? Many candles? A campfire?

“Our fire gives a friendly light;  
It lifts the darkness of the night.  
Its shining glow says this to me -  
A light to others I should be!”

A **TRAIL** can be a symbol.

“Which way to go? How can I know?  
When paths entwine, Which one is mine?”

“Two roads diverged in a wood, and I... I  
took the one less traveled by,  
And that has made the difference.”  
-- Robert Frost

What else could be a symbol? **Flowers? Stars? Dolls? Trees? Stones? Mirrors? Ribbons? Beads?**

## Colors:

Ask your girls what color they think represents a feeling or season. Colors may represent different things in different cultures, for example white is mourning in many Eastern cultures. Colors are not limited to the interpretations listed below.

Traditional Color Symbols		Colors of Seasons & Months	
Color	Meaning	Season/Month	Colors
Yellow or gold	Honor and loyalty	Summer	Yellow and green
Silver or white	Faith and purity	Fall	Orange and brown
Blue	Piety and sincerity	Winter	Red and black
Green	Youth and hope	Spring	Pink and green
Orange	Strength and endurance		
Black	Grief and sorrow		
Purple	Faith and purity	January	Black and white
Red	Bravery, courage, and sacrifice	February	Dark blue
		March	Gray or silver
		April	Yellow
		May	Lavender or lilac
		June	Pink or rose
		July	Sky blue
		August	Dark green
		September	Orange or gold
		October	Brown
		November	Purple
		December	Red

## Candles:

Candles are often used to remind people of the words and meaning of the Girl Scout Promise and Law. For young girls, use paper “candles” on poster board and have them stick on a flame (post-its work well). Use flashlights or LED candles when flames are not allowed. When using open flame have all hair tied back and use drip protectors of foil or heavy cardboard on any candles held by hand and have water nearby.

Some candle colors with special significance to Girl Scouts

Silver	the beginning of a new day, Cadette level achievements
Gold	Trefoil pin, Senior/Ambassador level achievements – highest level
Pink	all girls in Girl Scouts and Girl Guides
Yellow	Girl Scout Daisy
Brown	earth, Girl Scout Brownie
Green	plant life
Turquoise	water
White	purity

## Ceremony Planner

Print out this sheet and use it with your troop or group when planning your next ceremony.

Type of Ceremony	Bridging Court of Awards Girl Scout Birthday Girl Scout's Own Girl Scout Sunday Investiture/Rededication Juliette Gordon Low's Birthday Leader's Day Thinking Day Other _____
Purpose or Theme	Awards and Recognition Celebration Environment Friendship Girl Scouting History Peace Thank you Other _____

Date of Ceremony \_\_\_\_\_ Time \_\_\_\_\_

Length of Ceremony \_\_\_\_\_

Do invitations need to be made? \_\_\_\_\_

Who will attend?	
How will the Ceremony begin?	Who will do what?
What songs, poems, and quotations will be included?	Who will do what?

What will the main section consist of?	Who will do what?
Where will people stand or sit? Is special setup needed? (Make a sketch if necessary)	
How will it end?	Song Poem Flag Ceremony Friendship Circle, Taps Other _____
What decorations or props do we need?	Who will bring what?
Who will record the Ceremony for the Troop Photo book?	
Do we need a rehearsal? When will it be scheduled?	
Will refreshments be served? What will they be? Who will bring them? How many (#) and how much (\$)?	

## **SPECIAL CLOSINGS**

### **Clean Up**

(Good for young girls)

Girls skip around the room arranging everything neatly singing to the tune of “London Bridges”  
*Weave the magic in and out, in and out, in and out,  
Weave the magic in and out, we are Girl Scouts.*

*We have tidied everything, everything, every thing  
We have tidied everything, we are Girl Scouts.*

The girls line up before the leader who asks *Is everything finished?* Girls answer *Everything.*  
The leader asks *Is nothing left?* Girls answer *Nothing!* Leader responds *Then be gone!*

(Leader can wave a special “good-bye wand” as the girls silently tiptoe out)

### **Magic Tunnel**

When hats and coats are on, girls stand in two lines facing each other and raise arms holding hands to make an arch. The two farthest from the door go under the arch, then the next two, ... until the last two go.

### **Good-bye Song**

(tune Good Night Ladies) (Can be sung with Magic Tunnel)

Good-bye (name of level) (repeat 3 times), It’s sad to see you go.

### **Girl Scout Good-bye Song** (tune: Twinkle, Twinkle Little Star)

Now our Girl Scout meeting ends,  
Say good-bye to all our friends  
To our homes we Girl Scouts go  
Singing songs to let you know,  
We are happy as can be.  
Working, playing, merrily.

### **Girl Scout Out**

Stand in a circle with a girl in the center who touches each girl on the top of her head as she spells G-I-R-L S-C-O-U-T. The girls that get the letters O, U, T leave the circle and line up by the door (or given permission to leave with their designated adult). The next girl switches places with the girl in the center and the remaining girls close the circle and the spelling begins again. Repeat until everyone leaves.

### **Friendship Circle with Friendship Wish**

Girls stand in a circle with arms crossed right over left, grasping the hands of the person on either side. A designated person starts the passing of the friendship wish by thinking a silent wish and symbolically passing the wish to the next person on the right by squeezing her hand. That person thinks her own silent wish to pass, continuing the “squeeze.” When the originator receives the

“squeeze” she says “*God bless the Girl Scouts and Girl Guides everywhere. Good-bye.*” Girls drop hands and leave in silence.

This may be preceded by singing Taps.

Hint: To identify the location of the “squeeze” have each girl extend her right foot as she passes on her wish.

## Spread Arm Good-bye Circle

Girls stand in a circle with arms extended sideways at shoulder height, drop them halfway to your side, step one pace in and hold hands with the people two away (not right next to you). Every other person will be holding hands and arms will make an interesting zig-zag pattern. Sing a good-by song. You may want to try to lift up your arms to place them behind you without losing your hand hold.

## Native American Benediction

*Hand Motions:*

May the Great Spirit *extend right arm straight overhead*  
In the future *slant arm ahead*  
As in the past *slant arm behind*  
Be in our hearts *bring right hand on heart*  
As in our prayer *bring hands together at chest*  
*REPEAT using only gestures (no words)*

## Taps

*Hand Motions:*

Day is done *arms are held extended with palms down, shoulder level*  
Gone the sun *lower arms slightly*  
From the lakes *turn palms up, raise arms slightly*  
From the hills *raise arms higher*  
From the sky *raise arms level with top of head*  
All is well *lower arms to shoulder height, place right hand on left elbow*  
Safely rest *cross left hand to right elbow*  
God is nigh *bow head onto crossed arms*

## Variations

Daylight:

Thanks and praise, for our days  
`Neath the sun, `neath the trees, `neath the sky,  
As we go, this we know,  
God is nigh

Juliette:

On this day, we have come  
From the North, from the South,  
East and West, all your dreams  
Will live on, Juliette

Evening:

So good night, peaceful night  
`Til the light of the dawn shineth bright  
God is near, do not fear  
Friend, good night

Good Night:

Night has come, owls are out,  
Beetles hum round about  
Tip-toe so, out they creep  
Girl Scouts go home to sleep.

## **CANDLE LIGHTING INVESTITURE AND REDEDICATION**

**Need:** Small table, three large and ten small candles with holder, matches (or other means of lighting the candle), wood/cardboard trefoil with the Girl Scout Laws written on it, Girl Scout pin for each girl/adult involved (opened for ease of presentation)



Troop may march in and stand in a horseshoe facing audience if present. Begin the ceremony with the meaning of investiture. Then have participants say these or similar words while lighting the candles:

*These candles represent the three parts of the Girl Scout Promise.*

*The first candle I light shall shine as a symbol that Girl Scouts try to **Serve God and their country.***

*May the light of the second candle shine as a symbol that Girl Scouts try to **help people at all times.***

*May the light of the third candle shine as a symbol that Girl Scouts are true to their ideals as interpreted by **the Girl Scout Law.***

*Each of the ten candles in front of you represents a part of the Girl Scout Law.*

Ten girls (chosen previously) come forward, each taking a small candle, lighting it from a larger candle as she replaces it in the holder, recites the part of the Law assigned to her (Cue cards can be made from index cards with each girl's part of the law for her to hold)

Girls/adults to be invested come forward. They may be accompanied by another Girl Scout. Each new Girl Scout says the Girl Scout Promise and receives her pin.

As each leader (or registered Girl Scout) pins the trefoil she says something like *This pin tells everyone you are a Girl Scout. I know you will wear it proudly*" The pin may be pinned upside down. If so, the leader says something like *I have put your pin upside down. To affirm your belief in Girl Scouting, do something nice to someone and have that person put your pin on upright.* Then using the Girl Scout handshake, *Welcome to the Girl Scout organization and to Troop \_\_\_\_\_.*

After all new troop members have been invested, the leader may say to the group *Girl Scouts, the three leaves the trefoil wears and the three-fold message it bears, gives you as you start your Girl Scouting, the feeling that you are entering into a comradeship that will bring you joy as you work together, play together, and seek together. Today in every land this trefoil emblem points the way to sisterhood, friendliness, and good citizenship.*

Everyone returns to their place in the horseshoe and all the girls in the Troop say the Promise together. This rededicates them all to Girl Scouting. Close the ceremony with a song such as "When E'er You Make a Promise"

**SAFETY:** Candleholders may be made of wood, logs, or anything else. A pitcher or bucket of water should be nearby. A suggestion is that candles remain in place and a "lighter" is used to light them. The lighter can be another candle, a long wooden fireside match, a butane lighter. The each girl uses the lighter and gives it back to the leader so maximum control can be achieved for safety. Electronic candles can be used for younger girls or where open flames are not permitted.



## SAMPLE DAISY INVESTITURE

You will need: Daisy petals equal to the number of girls in your troop, a golden yellow center, a long green stem reaching toward the seated parents (wide enough for the girls to walk on), a leaf for each leader and assistant.

Tape everything in place on the floor before the meeting. Daisy pins and certificates for each girl may be placed on a small table by one of the leaders. Simple Daisy name tags may be made for girls and parents. (Be sure these are pinned to the right side of the dress or tunic of the girls to eliminate confusion when the girls receive their pins.)

Girl's take their place around the Daisy while the leaders take their place at the end of the stem by the table.

**Leader: Where are the girls who want to be Girl Scout Daisys?**

**Girls: Here we are!**

**Leader: You have agreed that you are ready to make a promise and receive your pin as Girl Scout Daisys. Let us make that promise together "On my honor..."**

**Assistant: \_\_\_\_\_ (naming girl), as a Girl Scout Daisy would you come forward?"**  
(Girl walks down stem to leaders.)

**Leader: "Welcome, \_\_\_\_\_. Here is your Girl Scout Daisy pin." She pins girl, shakes her left hand and makes the Girl Scout sign with her right hand. "And here is your certificate."**  
(And so on ---- until all of the girls are invested.)

**Leader: "Now let's sing our Girl Scout Daisy song. (Or "When E'er You Make a Promise.")"**

**Leader to Parents: Girl Scout Daisys are named after the founder of Girl Scouting in the United States, Juliette Gordon Low, whose nickname was Daisy. She brought Girl Scouting to the United States from England. Notice that the stem of our daisy leads to you. As parents, you are very necessary to the growth and development of our Girl Scout Daisys. We need to know your expectations for how "high" our Daisies will grow and ways that you can help us to reach that growth. We would appreciate your suggestions and participation. Would you please join us in a friendship circle (explains that) as our closing and stay for refreshments?**

Girls move back into larger circle--admitting parents as part of the group.

Have a friendship circle and refreshments. As refreshments are being set up, parents may help their daughter's place their invitations and the girls' certificates in the girls scrapbooks.

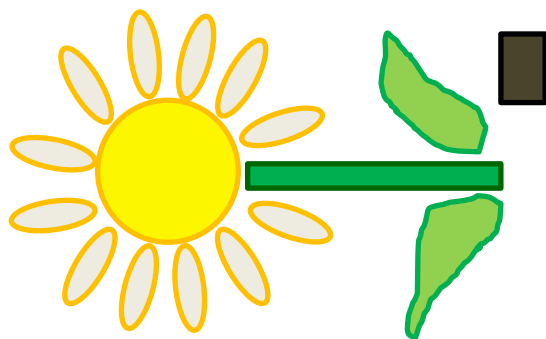

P	P	P	P	P
P	P	P	P	P
P	P	P	P	P
P	P	P	P	P
P	P	P	P	P
P	P	P	P	P
P	P	P	P	P
P	P	P	P	P
P	P	P	P	P

## **SAMPLE DAISY INVESTITURE CEREMONY**

Preparation: We requested and were given pizza cardboards from a local shop. Each girl cut out white petals and a yellow center and put her daisy on her cardboard. (On the brown side) We had a parent who had a collection of battery candles. Each girl was asked to bring two AA batteries to the meeting before Investiture that she could use for that night. This allowed (mostly) for any battery/bulb/ connection problems to be worked out ahead of time. You might want to eliminate this part, and just have your Daisies break through the ground!

(Daisies start by walking solemnly out holding battery candles from the back corner. As the leader speaks they form a line centered in front of all the Girl Scouts.)

**Leader:** *Each living thing begins as a small ray of light, of hope. The seed needs to be nurtured in order to grow. (Pause until all girls are lined up)*

*In Girl Scouts, the rays of hope are the girls of the world. Each seed is planted with love. The value of each young girl is recognized by older people: parents, siblings, friends, neighbors, leaders, and community members. Our Daisies have been nurtured in their homes and in their community. They are now ready to bloom!*

*Troop #\_\_\_\_'s Daisy meetings will be a place where each girl's individuality is valued. It will be a place where the importance of caring for ourselves and others will be emphasized. We'll learn about our world and ways to care for nature. We'll have fun! Our troop will be a place for each girl to discover, connect, and take action to make the world a better place.*

**Leader:** *We are here to greet the newest buds in the Girl Scout world. Its time for our new Daisies to emerge!*

(All Daisies turn off candles and give to assistant. New Daisies form a line behind a brown curtain ("soil") with an opening in the middle. (We used two pieces of felt pinned over a rod.))

**Leader:** *While the girls are moving to their places, would a parent or caregiver of each Daisy please come forward and be ready to pin on the Daisy pin and help us recognize our newest Girl Scouts? (New Daisies behind the brown "soil" felt, round daisy pizza cardboards in hand. Parents cluster on the side. )*

*Daisy Troop #\_\_\_\_ presents our newest flowers*

(Say each Daisy's name as she emerges and each girl holds up her daisy circle and walks to her parent/caregiver "pinner").

**Leader:** *Thank you for your help, parents! Please return to your seats so we can sing for you.*

*All Daisies sing "I'm a Girl Scout Daisy"*

## **BROWNIE POND INVESTITURE**

### **Props Needed:**

**Brownie Girl Scout “Pond”** (can be constructed from a piece of cardboard covered with foil and border with greenery, or use a mirror and border with greenery, or use a real one!)

**Brownie Pins** for each new member. They can be placed on the floor by the pond.

Lay pond on the floor in the middle of the ceremony area. If desired, new members can be sent outside with the Co- leader. If new girls stay in the room, they should be on one side of the pond and the other girls should be on the other. All stand or sit around the “pond” and then the leader says the magic words:

**Leader:**                    *Cross your little fingers, stand upon your toes  
That’s a bit of magic every Brownie knows  
Now we all are standing in a forest glade  
Listen very carefully, see the magic made*

If the new Brownies have been sent outside, the girls knock on the door

**Co leader** (with the troop): *“Who comes to the Brownie woods?”*

**Brownies-to-be:**        *We do*

**Leader:**                    *What do you want?*

**Brownies-to-be:**        *We want to be Girl Scout Brownies*

(optional) **Leader:**    *Why?*

the girls may give their own reasons (help them prepare them before the ceremony if you plan on asking). **Brownies-to-be:** enter and gather around the pond. At this point you may have a simple dramatization of the Brownie Story by the older Brownies or the leader may tell or read the story to the girls.

**Leader:**                    *Who comes first (or next) to the Magic Pond?*

**Co-Leader:** (Reads girls names, one by one, alphabetically)

**Leader:** Turns girls, one by one, while saying:

*Twist me and turn me and show me the elf  
I looked in the water and saw \_\_\_\_\_*

**Brownie-to-be** (individually): *Myself!*

Leader pins on Brownie Pin, gives the girl the Girl Scout handshake and welcomes her to Girl Scouting.

After each girl receives her pin,

**Leader** says:            *Uncross your little fingers, down from off your toes  
Then the magic goes away, everybody knows*

Older Brownies can help clean up the “magic” while the leader and girls sing this song:  
(Sung to the tune of London Bridges)

*Weave the magic in and out, in and out, in and out  
Weave the magic in and out, for we are Brownies  
We have tidied everything, everything, everything  
We have tidied everything, for we are Brownies*

## SAMPLE REDEDICATION #1

Everyone stands in a horseshoe. A table at the opening holds ten small candles and one large candle.

Leader	<i>A candle's but a simple thing It starts with just a bit of string Yet dipped and dipped with patient hand, It gathers wax upon the strand Until complete, and gleaming bright, It gives at last a lovely light.</i>	while lighting the large candle
Co-Leader	<i>This first large candle represents the spirit of Girl Scouting, the Promise.</i>	
Girl 1	<i>Let us now say the Promise.</i>	She leads everyone in the Promise
Girl 2	<i>Let us now sing (song chosen by girls)</i>	She leads them in song
Girl 3	<i>I will do my best to be honest</i>	Lights first small candle
Girl 4	Recites second part of Law	Lights second small candle
Girls 5-11	Continues reciting parts of Law and lighting small candles	
Leader	<i>Life is like that bit of string Each deed we do a simple thing Yet day-by-day, if on life's strand We work with patient heart and hand It gathers joy, makes dark days bright... And gives at last a lovely light</i>	



## **GORP REDEDICATION #2**

**Check for allergies to ingredients before making this or adjust items and words!**

*Have you ever wondered what goes into making a Girl Scout? Well, we have a recipe to show you what we're all about.*

1. *Girl Scouts come in all colors, from all cities and towns,  
Every Girl Scout's a sister no matter what she looks like or how she sounds.*

**Add M&Ms to the bowl**

2. *Some of us are tall, and some of us are small  
When we get together, size doesn't matter at all.*

**Add pretzel sticks and marshmallows**

3. *With our words and actions, we show that we care,  
We try to do our best to be fair and square.*

**Add Chex cereal to the mix**

4. *Sometimes we act a little "nuts," we love to joke and play  
We'd love to put a Girl Scout smile into everyone's day*

**Add nuts to the bowl.**

5. *When we get together, we make circles so round*

**Add Cheerios to the mix**

*It's our never ending friendships to which we are bound.*

6. *When we're planning and working, we just don't stop,  
We keep ourselves busy; all around we will pop.*

**Add popcorn**

7. *We respect all God's creatures, if they're big or they're small,  
The earth is our home, and there's room here for all.*

**Add Animal Crackers or Goldfish Crackers**

8. *It was 1912 when Juliette Low started us off,  
And like the girls back then, we're just "chips off the old block"*

**Add butterscotch, chocolate, and white chocolate chips**

9. *We get a "kick" out of learning and doing new things,  
And a "kick" out of helping others, and spending time with friends.*

**Add Kix cereal**

10. *When we were (previous grade level) we were fresh, new, and rare,  
But now we're (next grade level) and have experience to share.  
Added together, the number of year our girls  
have spent in Girl Scouting comes to \_\_\_\_.*

**Count out loud the number of raisins or each girl can  
contribute raisins for each year she's been a Girl Scout**

11. *Now we stir to the left and we stir to the right,  
We mix it together with all of our might.  
We welcome our troop to another great year,  
And hope the memories we make, we will always hold dear.*

*Now that our recipe is complete, we look upon what we have created. Each of the ingredients went into our recipe separately, just like each of the girls came into the troop separately. As*

*the ingredients mix together to form one dish, our girls mix together to form a troop. But even as we look upon our mix, we can still see each ingredient as separate and unique. Our girls bring each of their own unique talents and characteristics to our troop to make it what it is.*

**Girls Sing:**

*When you make a Gorp mix,  
Consider well its ingredients,  
And when made,  
In it we can see ourselves*

(from [www.scoutingweb.com](http://www.scoutingweb.com))

## HOW TO BAKE A BROWNIE

(A fun Daisy Bridging Ceremony the girl's will love)

2 tables lying on their side length-wise, with a LARGE cardboard box in the middle. (try a TV dealer for this box). On the box, cut an oven door, with a handle made from cardboard or foil. "Old" Brownies do all the motions, and bridging Brownies stay behind the tables.

You'll need 2 bowls, 1 large, and 1 small. flat baking pan, mixing spoon, measuring bowls, sifter, measuring spoons, and kitchen timer, Brownie Girl Guide to Girl Scouting Handbook.

Current Brownies are in an open horseshoe.

1<sup>st</sup> Brownie: *Let's bake something.*

2<sup>nd</sup> Brownie: *Yes, what can we do about it?*

3<sup>rd</sup> Brownie: *I know, let's make some new Brownies !*

All girls - *Yes, Yes, Yes*

4<sup>th</sup> Brownie: *Let's look in our handbook for the recipe. (all pull out handbooks.)*

5<sup>th</sup> Brownie: *Here it is! To make Brownies, we must mix some Basic ingredients like the Promise and Law, fun and laughter, and a sprinkle of badges!*

6<sup>th</sup> Brownie: *In a large bowl, cream together 1 cup of each of a promise to serve God, my country and mankind.*

7<sup>th</sup> Brownie: *to this mixture add 2 cups of honesty and 4 tablespoons of cheerfulness. Mix together until well blended.*

8<sup>th</sup> Brownie: *stir in 1 cup of thoughtfulness.*

9<sup>th</sup> Brownie: *beat together 1/2 c of fairness and 1/2 c of helpfulness and add to the mixture.*

10<sup>th</sup> Brownie: *sprinkle over the mixture 2 tablespoons full of sisterhood of Girl Scouting and mix well.*

11<sup>th</sup> Brownie: *add 1 c of respect for authority and 1 c of respect for myself and others. Stir until well blended.*

12<sup>th</sup> Brownie: *sift together 1/2 c of wise use of resources and 6 Tbs of a promise to protect and improve the world. Stir into mixture.*

13<sup>th</sup> Brownie: *4 tsp discoverer, 4 tsp ready helper, 4 tsp friend maker and add to the mixture.*

14<sup>th</sup> Brownie: *spread batter into the pan and bake at a moderate temperature until done.*

15<sup>th</sup> Brownie: (after timer rings) *They're done!*

(open door and new Brownies start to crawl out of the oven.)

Everyone: *Look!! A NEW BATCH OF BROWNIES!!!*

## **DAISY BRIDGING TO BROWNIE CEREMONY**

(Adaptable to any level)

Each GS DAISY who is Bridging receives a Daisy.

OLDER GS: These flowers represent the spirit of Girl Scouting. This spirit is often represented with the Daisy, which was our founder, Juliette Low's, nickname.

OLDER GS: The first three flowers represent the three parts of the GS Promise.

GS DAISY: On my honor, I will try: To serve God and my country

GS DAISY: To help people at all times

GS DAISY: And to live by the GS Law

GS DAISY: I will do my best: To be honest and fair

OLDER GS: This means that you will always tell the truth and that you will share things and take turns with others.

GS DAISY: To be friendly and helpful

OLDER GS: This means that you will ask a new girl to play with you and when you see a job that needs to be done, and you can do it, you will be willing to help do it.

GS DAISY: To be considerate and caring

OLDER GS: This means that you will respect the feelings of others and care about how they feel and what they think.

GS DAISY: To be courageous and strong

OLDER GS: This means you are willing to try new things, even though you may be a little scared and that you will stand for what is right.

GS DAISY: To be responsible for what I say and do.

OLDER GS: This means that you will be careful about what you say and do so that you don't hurt other people or things.

GS DAISY: To respect myself and others

OLDER GS: This means you will try to be the best person you can be, and will be courteous to others.

GS DAISY: To respect authority

OLDER GS: This means you will respect adults, obey the law and will cooperate with others.

GS DAISY: To use resources wisely

OLDER GS: This means you will try not to waste paper, will turn off the lights, and turn off water faucets after you use them.

GS DAISY: To make the world a better place

OLDER GS: This means you will help with a neighborhood clean up, put litter in trash cans, and treat all animals kindly.

GS DAISY: To be a sister to every GS

OLDER GS: This means you will be a kind friend to everyone, not just to a few people.



## GIRL SCOUT'S OWN

A **Girl Scout's Own** is a quiet type, usually a reflective type of ceremony with a theme. It is called a Girl Scout's Own because the girls and leaders plan it themselves. It is not a religious service or ceremony and does not take the place of going to church, temple, or synagogue. It is an occasion to express their deepest feeling about subjects which are meaningful to them.

A Girl Scout's Own can be held at any time, indoors or out, at a troop meeting, inter-troop meeting, or camp. Usually these are planned by girls who are Juniors or older. Brownies may begin to sense the deeper values in Scouting as they hear others express their feelings, convictions, aspirations, or ideals when they participate.

First choose a **THEME**. Examples: friendship, sisterhood, the beauty of nature, the life of Juliette Lowe, the first day of spring, flags, citizenship, service, the world of tomorrow, senior citizens, thankfulness... Make a list of the different ways you can tell or show your theme such as songs, poems, choral rendition, stories, plays, music played on an instrument, pantomime, ... or thoughts about what the theme means to each Girl Scout. From the list chose one idea to open the ceremony, then two to six ideas to include. Decide how to end the ceremony.

Choose a **SPECIAL PLACE** to hold the Girl Scout's Own. If outdoors, you may want a place with a view or under a special tree. If indoors, you may choose a symbol like a flag or special picture or scene.

Choose **who** will perform or lead each part and who will lead the girls to the ceremony location and back again.

It is a Girl Scout custom to **walk quietly** to the special place where the ceremony is held, often with participants going under an arch (of hands) or after walking by something special (a tree, a picture). Everyone leaves quietly after it is over.

The plans for every Girl Scout's Own should provide for definite, thoughtful leadership – which will quietly maintain the essential qualities of reverence and aspiration

Keep the ceremony short – 10 to 15 minutes – but in the atmosphere of quiet expression and free exchange of earnest feeling, allow the girls their full share, both in the planning and in carrying out the ceremony.

## WAGGGS Friendship Knot Instructions

**WAGGGS Friendship Knot** symbolizes the ties which bind girls and adults who belong to the World Association of Girl Guides and Girl Scouts and is a sign of the continuous friendship they share. The four ends of the knot represent the Promise, the Girl Scout Law, the Motto, and Service to others. The four squares stand for the four World Centers: Pax Lodge in London, England; Our Chalet in Adelboden, Switzerland; Sangam in Pune, India; and Our Cabana in Cuernavaca, Mexico.

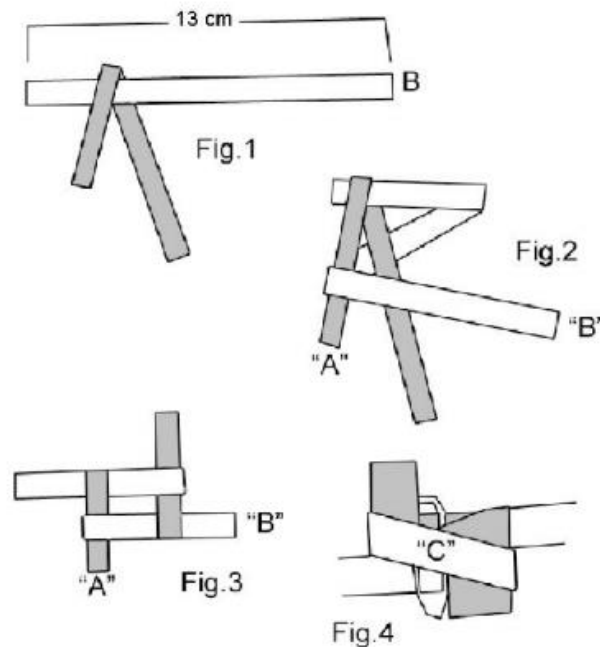

[http://www.gsnc.org/resource\\_room/documents/WAGGGSFriendshipKnotdirections.pdf](http://www.gsnc.org/resource_room/documents/WAGGGSFriendshipKnotdirections.pdf)

Instructions to tie a swap: Using two pieces of ribbon 5" long and ¼" wide and a small safety pin.

Fig. 1: Two pieces A and B. Fold A over B at one end of B.

Fig. 2: Fold B behind both parts of A and around to the front of both parts of A.

Fig. 3: Weave the long end of A over B's end and under B's loop. Pull gently to make the four ends of the knot even.

Fig. 4: You can slip a safety pin under the cross piece (C) in the back to make a swap.

This is also known as a Japanese crown knot and success knot.

## WORLD FLAG CEREMONY

This ceremony provides an explanation of the meaning of the World Flag and can be adopted for a World Pin Ceremony



### **Materials needed:**

Oblong of blue material in color of World Flag. Some of this may be mounted on cardboard and from it cut the two stars and compass needle.

Yellow material from which are cut the trefoil and flaming base (2 separate pieces.)

1. **WHAT IS THE WORLD FLAG?** This is the flag of the World Association of Girl Guides and Girl Scouts. It was adopted in 1930 at our 6th World Conference to symbolize the world-wide bond of Scouting. It is an emblem that has deep meaning for all Girl Guides and Girl Scouts. Let us construct a World Flag and consider very carefully as we do so the reason for its color and design. Then we shall know how much this World Flag should really mean to our Girl Scouts and how deep a feeling of international friendship it should inspire in us.

2. **WHY IS THE WORLD FLAG BLUE?** (Put up the blue background) We chose a field of bright blue in our World Flag to symbolize the sky above us all throughout the wide, wide world. We thus carry out the words of Baden-Powell, Founder of Scouting, who asked us to "AIM HIGH, LOOK WIDE."

3. **WHY DO WE HAVE A TREFOIL ON THE WORLD FLAG?** (put up yellow trefoil) Upon the background of the blue we place a Trefoil of Gold, the emblem of Scouting in all countries.

4. **THERE ARE TWO STARS ON THE WORLD FLAG. WHAT DOES ONE OF THEM STAND FOR?** (Place blue star on Trefoil's left) We place one star at the left – the site of the heart. This star stands for the pledge that all Guides and Scouts try, on their honor, to keep, that is, our Promise.

5. **WHAT DOES THE OTHER STAR STAND FOR?** (Put star on right side) On the right side of the trefoil, the side of the ready and helpful hand, we place the star, which stands for our Scout Code of Conduct - the Law.

6. **WHAT DOES THE POINTER MEAN ON THE WORLD FLAG?** (Place blue compass needle in the center of the trefoil) We place a compass needle, TRUE BLUE, in the Center of the Golden Trefoil, between the safeguards of the Promise and the Laws, to serve as a guide to show us the Right Way of Life.

7. **WHY DOES THE TREFOIL HAVE ROOTS?** (Place root at base of trefoil) At the base of the Golden Trefoil we place a flame-like root. This burning root is a symbol of International Friendship.

8. **CONCLUSION** Whenever Girl Scouts and Girl Guides are gathered together, we fly this flag. At every national or International Girl Scout Conference, we fly this flag. For every Girl Guide and Girl Scout, alone or in a troop, who knows these symbols and tries to live up to them, we fly this flag.

## AMERICAN FLAG PROTOCOLS

Girl Scouts have no official policy on flag usage. An attitude of respect for the American Flag as a symbol representing our country, the United States of America, should be displayed when following various protocols. The GSGLA Camping Skills Manual will provide suggested outdoor flag ceremony procedures.

<http://www.usa-flag-site.org/> and <http://www.usflag.org>

### **Rules for Display of the American Flag:**

Other flags may be smaller but none larger (can be the same size) than the U.S. flag when displayed with other flag. No other flag should be placed higher (above) the U.S. flag. In a line or on a stage, the US flag is to the **right** when facing the audience (audience sees it on the left), to the **right** of a speaker, to the **right** on a table. The blue of the flag should be to the **right** of the flag when hung on a wall or to the north or east when hung where both sides may be viewed. The flag should be lighted at all times by sunlight or other light source.

### **Raising and Lowering the Flag:**

The American flag (also referred to as the Colors) should be raised briskly and lowered slowly and ceremoniously. It should be illuminated if displayed at night. It is saluted as it is hoisted and lowered. Honor guards may salute the flag briefly before lowering or after it is raised. During the raising or lowering they do not salute, but watch the flag to assure it is attached securely and to receive the flag as it is lowered to assure it does not touch the ground. The honor guard folds the flag and presents it to the flag carrier for transport. When carried with one other flag it is carried on the right, when carried with two other flags, it is carried in the center.

### **Participants in Flag Ceremony:**

Girl Scouts in a Color Guard\* (flag bearer and guards) open to the public are in full uniform and often wear white gloves. In the troop, the American flag should be handled with dignity and a uniform is not essential. While camping, the Color Guard may wear red sashes. Reverence and respect should be demonstrated by everyone during a Flag Ceremony.

\*When multiple flags are presented/retired, each flag should have its own color guard.

**Audience:** The audience forms a horseshoe facing an opening where the flag will be presented and stands when the flag is being carried and participates as directed by the caller.

**Caller:** Directs the ceremony near the front for everyone to hear and participates with the audience for the Pledge of Allegiance.

**\*Flag Bearer (O):** Carries the flag and raises/posts or lowers/retires the flag. (Sash over right shoulder tied in a square knot on the left hip)

**\*Guards (X):** Sees that the US flag does not touch the ground, holds the flag while flag bearer attaches it for raising, sees the flag flies free, catches and folds the flag when lowered and presents it to the bearer. (Sash around waist with square knot on left hip). Color guard does not sing, speak or join audience in salute and stands at attention when not involved in raising/lowering responsibilities. Usually there are two, four, or more color guards per flag. To honor the flag (put right hand over heart for about 2 seconds) right after the flag is raised to the

top of the pole/posted, or just before being lowered/retired when the caller asks the Color Guard to “Honor the Colors”.

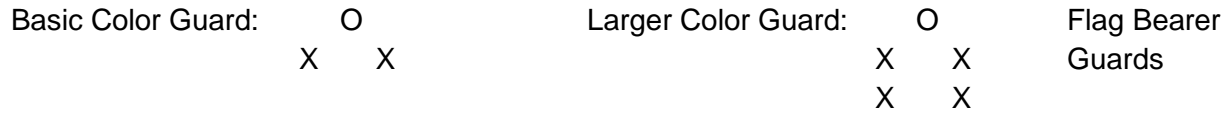

The Flag Bearer may hand the flag to one of the guards while the clasps are brought into position and fastened, attaching the flag to the pole. Guards are responsible for seeing the flag flies free before it is raised and catching the flag as it is lowered so that it does not touch the ground.

If a flag attached permanently to a staff is held during a ceremony, the “Color Guard Advance”s to a position facing the audience. (US flag remains upright and other flags are tilted forward about 30°). “Color Guard Retire” has the Color Guard wheeling to the right to place the colors in their original positions. To Post the colors means putting the flag(s) in the flag stand(s).

### **Flag Folding:**

The Flag Bearer faces the pole while the guards fold the flag. The blue field should be nearest the flag pole and folded down. All flags should be folded lengthwise first to facilitate the next raising. The US flag is folded twice lengthwise with the stars on the bottom when horizontal. Guard holds flag taut while one member starting from the striped end folds in triangles. The grommet edge is tucked into the pocket and in the triangle with four stars on top. The color guard reforms into its original positions and triangle (point forward) is presented to flag bearer who holds it horizontally with point outward. The guards then take one step outward to allow the flag bearer to pass through the aisle they form after which the first couple closest to the pole turns to follow, and so on, until they all are in line to leave the area. (Other flags are folded into a rectangle.)

### **Retiring a Worn Flag:**

This is a very solemn ceremony done with the utmost respect usually during a Girl Scout campfire. Using sharp scissors, a flashlight, long tongs or fireproof gloves the stripes are ceremoniously cut and laid on the fire one-by-one with the field of stars last. If you participate in a combined Indoor Overnight/Camping Skills overnight training you may participate in or observe a retirement ceremony for a worn flag at your campfire.

“When the flag of our country has become worn or damaged, the proper way to dispose of it is through burning or burial. We are here tonight to pay our last respects to this flag with love and reverence. Each stripe stands for one of the original thirteen colonies, and each state is represented by a star on a field of blue.” The first stripe (from the bottom) stands for Delaware, then Pennsylvania, New Jersey, Georgia, Connecticut, Massachusetts, Maryland, South Carolina, New Hampshire, Virginia, New York, North Carolina, Rhode Island. The field of blue which stands for all the states is burned last, laid on the fire with two girls holding the corners, not tossed onto the fire.

## **CALLS FOR A FLAG CEREMONY**

Flag Posting:

<b>Flag Ceremony raised on a flag pole</b>	<b>Flag Ceremony with a flag on a staff</b>
Color Guard, Attention	Color Guard, Attention
Please stand for the Colors and remove your hats	Please stand for the Colors and remove your hats
Color Guard, Advance	Color Guard, Advance
Audience, Please place your hand over your heart Color Guard, Hoist the Colors	Audience, Please place your hand over your heart Color Guard, Present the Colors
Color Guard, Honor the Colors	Color Guard, Honor the Colors
Please join me in the Pledge of Allegiance: I pledge allegiance...	Please join me in the Pledge of Allegiance: I pledge allegiance...
Color Guard, Dismissed	Color Guard, Dismissed

Flag Lowering:

<b>Flag Ceremony lowered from a flag pole</b>
Color Guard, Attention
Please stand for the Colors and remove your hats
Color Guard, Advance
Color Guard, Honor the Colors
Audience, Please place your hand over your heart while the flag is lowered. Color Guard, Retrieve the Colors
Color Guard, Dismissed

Slight variations may be used to make the flag ceremonies more meaningful to the girls in your troop meeting.

“Salute the flag” might become:

- Today, let us salute the flag in honor of our founding fathers who had visions of today’s America
- Join me in saluting the flag of our country, the emblem of truth and justice!
- For the opportunities our country offers the youth of America, let us now salute our flag, the emblem of our nation.
- In the folds of our flag are enshrined every ideal, hope, and opportunity made possible because someone has lived. Let us salute our flag!
- The flag of the United States of America is the emblem of our nation – the leader of the free world. Let us now salute our flag!

The girls may want to add the singing of "America the Beautiful", "America, My Country 'Tis of Thee" or other patriotic song after the Pledge of Allegiance.

### **FLAG (RECIPE) CEREMONY**

- |          |   |
|----------|---|
| 6 girls  | 1 cup each red blue & white chips or crepe paper cut up<br>1 large soup pot<br>1 large Spoon<br>American Flag<br>Stars (glitter or white stars, cut from paper)               |
| 1st girl | "We are going to fix for you a treat that is really grand, and make for you a recipe – the greatest in the land."   |
| 2nd girl | "In first, we will put a heaping cup of RED for courage true."  |
| 3rd girl | "And then we will add for loyalty, a dash of heavenly BLUE".  |
| 4th girl | "For purity, we will now sift in a layer of snowy WHITE".   |
| 5th girl | "We will sprinkle a pinch of stars (GLITTER or WHITE STARS) to make it come out right."   |
| 6th girl | "We will stir and stir and then you'll see that what we have made is...."   |
| ALL      | "Old Glory" - pulls out folded flag from the bottom of pot and hold up for Pledge and song. "Our flag is the most beautiful flag in the world, let us always be loyal to it." |

It is suggested that the six girls leave their places in a horseshoe around the pot facing the group. All pull out the flag together. A spotlight is also nice.